

TOTALMOVE





TOTALMOVE



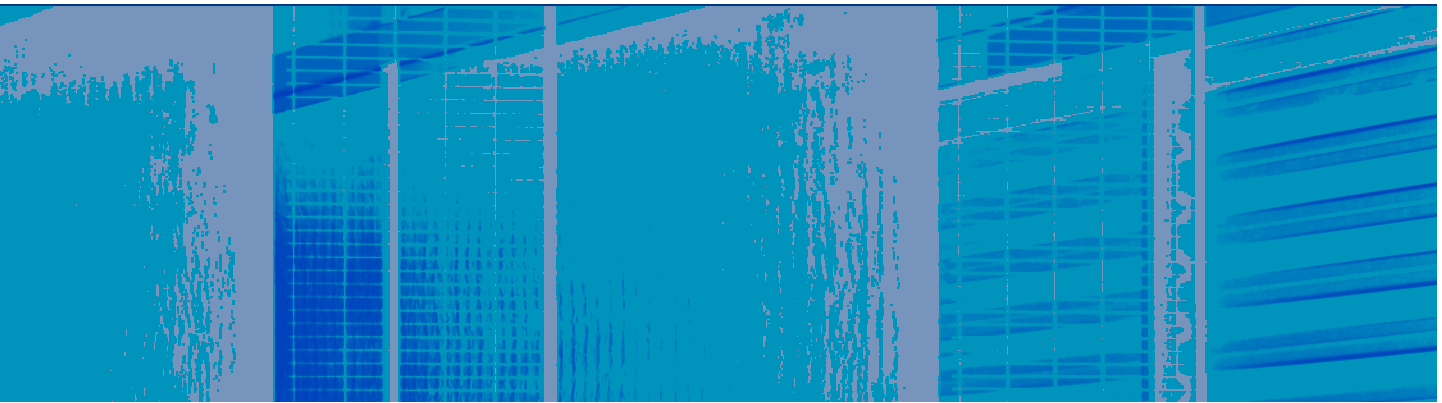

The Totalmove 30 L platform allows a person on-board the vehicle and is certified for travel up to 11 meters.

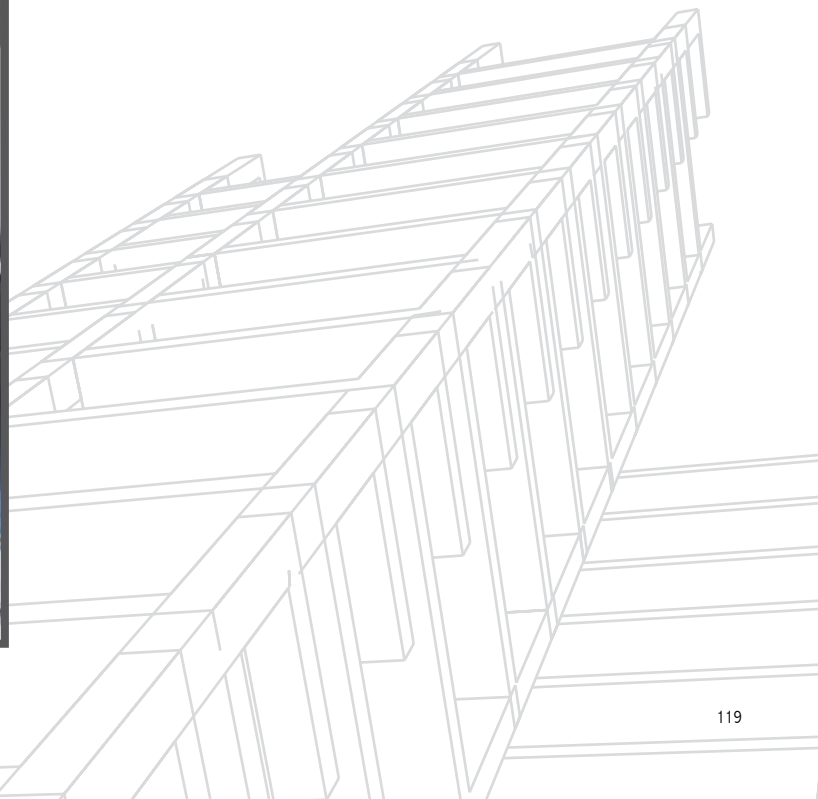



The platform has a 2.50 mt high guard which can only be removed using special maintenance tools, thus preventing contact with the moving parts of the platform (complaint with EC 2006/42).





This photo shows in detail the operator control panel on-board the platform and all the pushbuttons for operation and platform safety. It also shows the interphone, connected to a telephone dialer (standard), which holds seven numbers in memory for repeat dialing, plus twenty-two country codes so the unit can be adapted to the national telephone network.



The short ends of the platform both have photoelectric barriers, each composed of two photocells that block the unit if the vehicle on-board should move abruptly or risk bumping against the wall during operation. This feature ensures that the vehicle is always correctly positioned.





The photo shows how easy it is to install the electric and hydraulic connections located in the pit under the platform, between the two columns.

Details of how the column is secured to the wall using plates prewelded to the column and chemical anchors. The photo also provides details of

the lift chain and pulley connection. A protection is secured on the outside of the pulley to prevent the chain from leaving its seat.





A system of limit switches set at the base of the piston control tension of the lift chains (two per piston) and ensure that the platform is locked in case of malfunction or if one of the chains should fail.



The photo above shows an example of the limit switch positioned on the unit.



The photo shows the deceleration and travel regulation limit switch in action, highlighting the length of the operating cam (longer than the stop cam).



Indeed, this angle shows operation of the stop limit switch, located on the column opposite the deceleration limit switch, and highlights the shorter operating cam.



This series of photos shows the mechanical assembly that hydraulically locks the platform to the floor.





The shoulder of the platform passes beyond the point where the piston is mechanically blocked to the floor, thus allowing it to protrude.

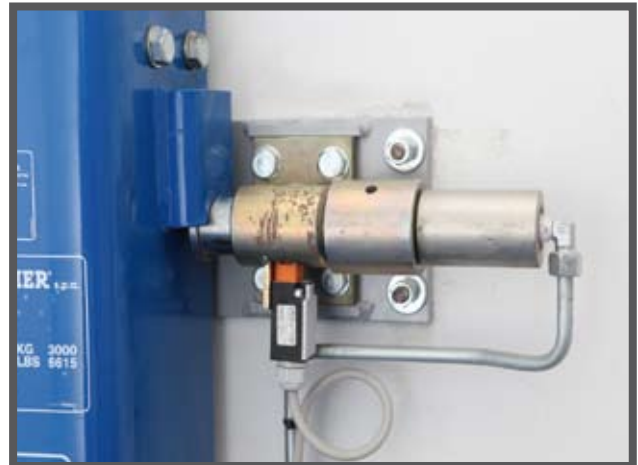

Then the shoulder drops down again and the connection block engages so that it rests on the piston itself, protruding from its housing and ensuring overall stability. At this point the hydraulic lift system of the two pistons under the platform revert to the resting position, preventing the continuous stress the hydraulic circuit would be subject to if they were to remain constantly pressurized.

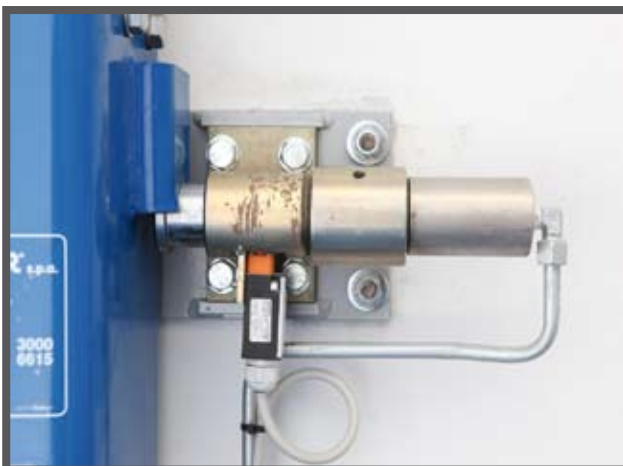

The piston that mechanically locks the unit to the floor is further controlled by an “all out, all in” limit switch that analyzes the correction position.

Note that this platform does not present any movement as the vehicle drives on, a condition which would be seen if the platform were supported only by the pressure of the pistons. Indeed, this condition is easier on the user’s peace of mind.

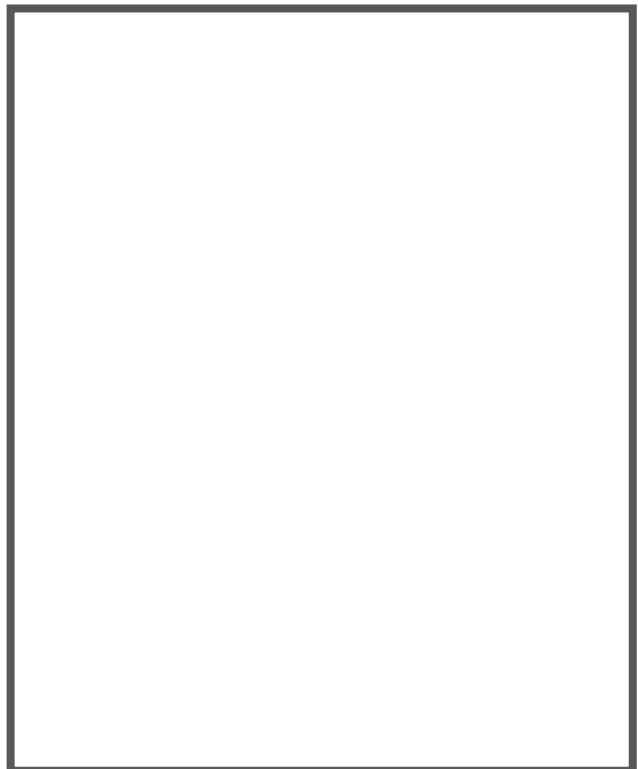



The photo, seen from below, shows the column with the lift cylinder (manufactured by O.M.E.R. S.p.A.), rack with torsion bar, catenary protection of the power cables on-board the platform and the electrical junction box.

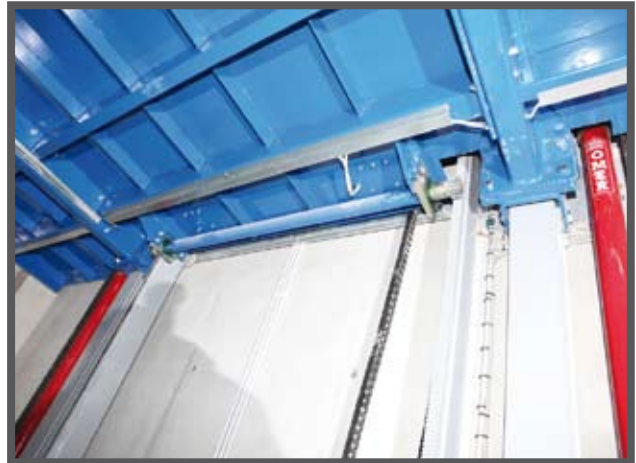

The head pinion on the torsion bar has a notched ring (one on each end) that is engaged and runs along the rack (one per column). The same torsion bar has position-adjustable supports so that it is perfectly coupled to the racks.



The unit has a torsion bar system that engages the two racks fixed to the sides of the two columns. This system makes it possible to distribute the weights over the platform, even if they are off-center, thus making it possible to use the lift for goods as well as motor vehicles.



The view of the platform from below shows the various elements that stiffen the platform, ensuring that it is rigid and cannot bend, even with side or off-center loads.



Detail of the front wheel stop to guarantee that the vehicle is properly positioned and to prevent it from shifting while the platform is being moved. Another such stop is found at the back.



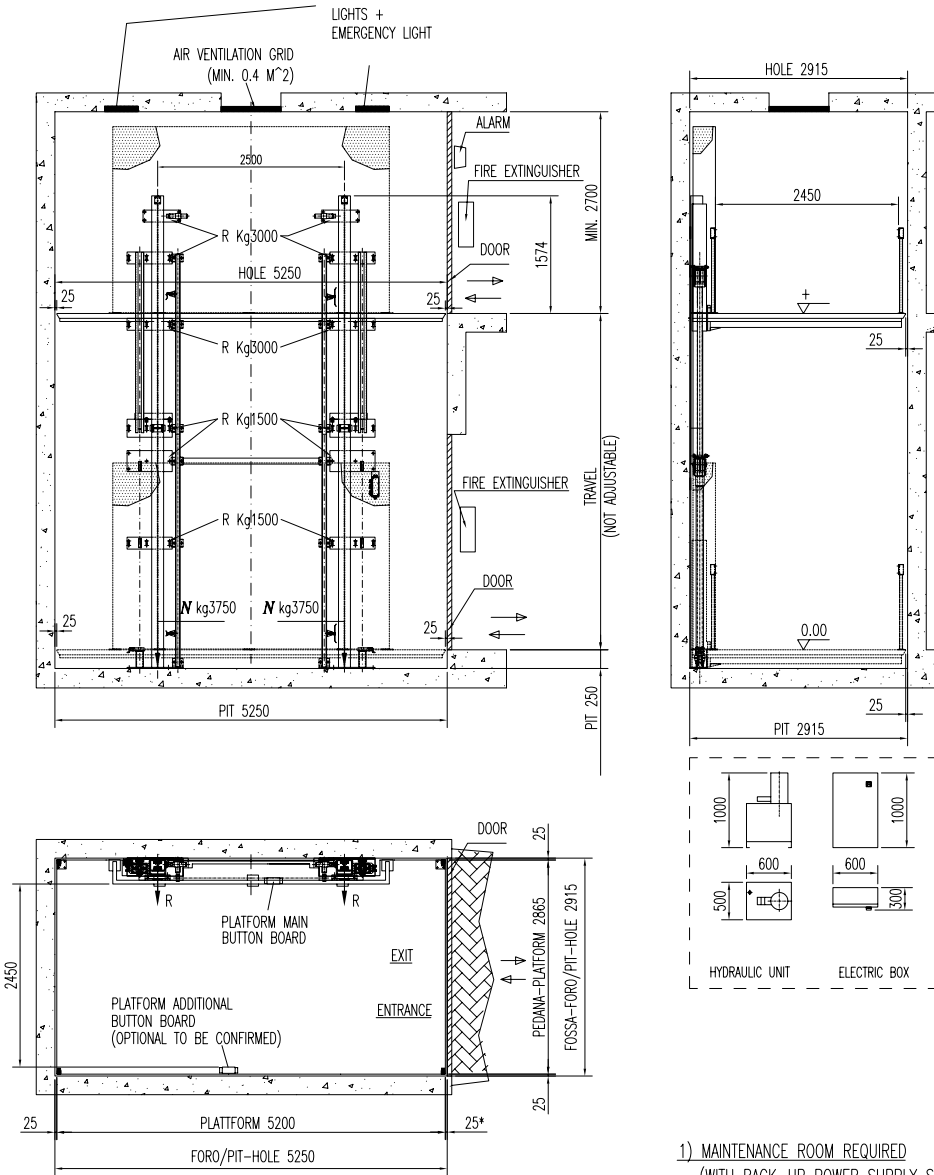

(*) PLEASE LET TAKE INTO ACCOUNT THAT A CLEARANCE <25 mm HAS TO BE MANDATORY

- 1) MAINTENANCE ROOM REQUIRED
(WITH BACK-UP POWER SUPPLY SYSTEM
IF ELECTRIC DOOR ARE INSTALLED)
- 2) ELECTRICAL BOX 600x300x1000 LxBxH
- 3) HYDRAULIC GROUP 600x500x1000 LxBxH

	Capacity	Standard Lifting Height	Max Lifting Height	Minimum Lifting Height	Standard Platform	Max Platform	Platform distance	Pit	Power	Speed	Power supply	Standard Weight	Notes
TOTALMOVE	3.000 kg.	4.000 mm	11.000 mm	2.000x4.000 mm	2.865x5.200 mm	3.000x5.600 mm		250 mm	4/7,5 kw	0,06 m/s	400 v / 50 hz	3.700 kg.	
	6.608 lbs	157,5 inch	433,1 inch	78,7x157,5 inch	112,8x204,7 inch	118,1x220,5 inch		9,8 inch	5,5/10,2 hp	2,4 inch/s	400 v / 50 hz	8.150 lbs	

TECHNICAL DATA SHEET AND ACCESSORIES

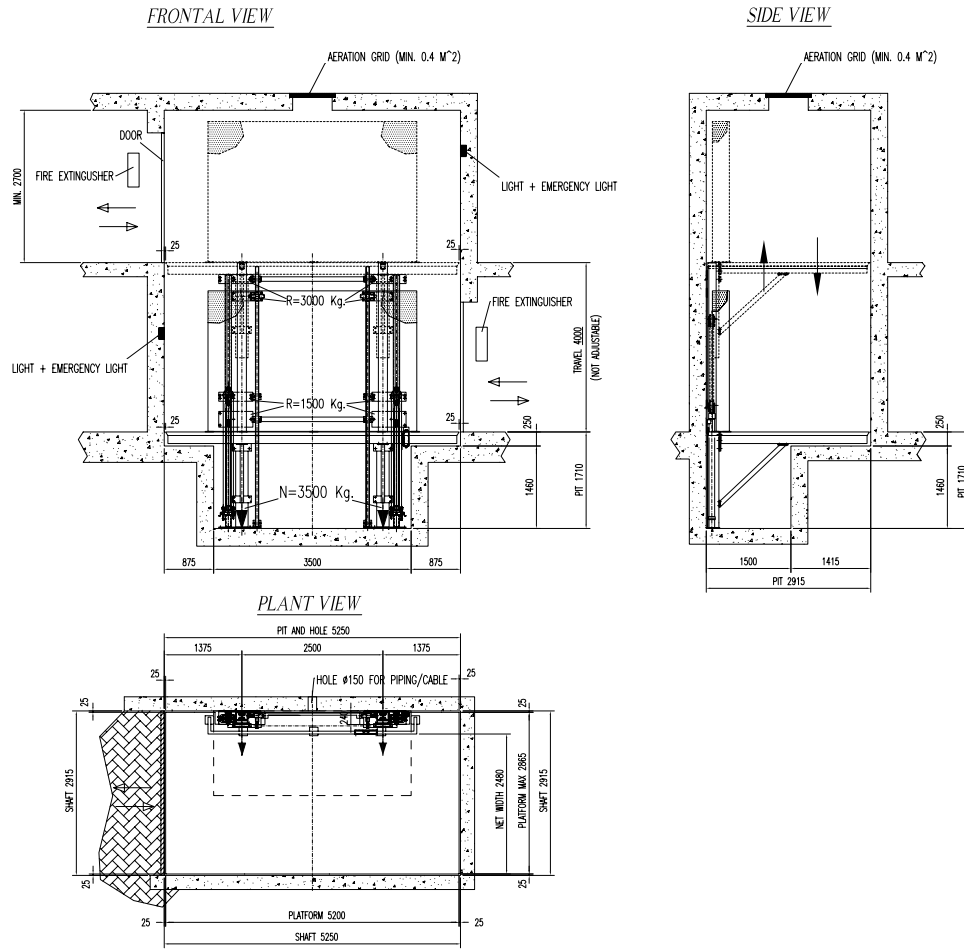

- 1) MAINTENANCE ROOM REQUIRED
(WITH RACK-UP POWER SUPPLY SYSTEM
IF ELECTRIC DOOR ARE INSTALLED)
- 2) ELECTRICAL BOX 600x300x1000 LxBxH
- 3) HYDRAULIC GROUP 600x500x1000 LxBxH

CONTROL UNIT

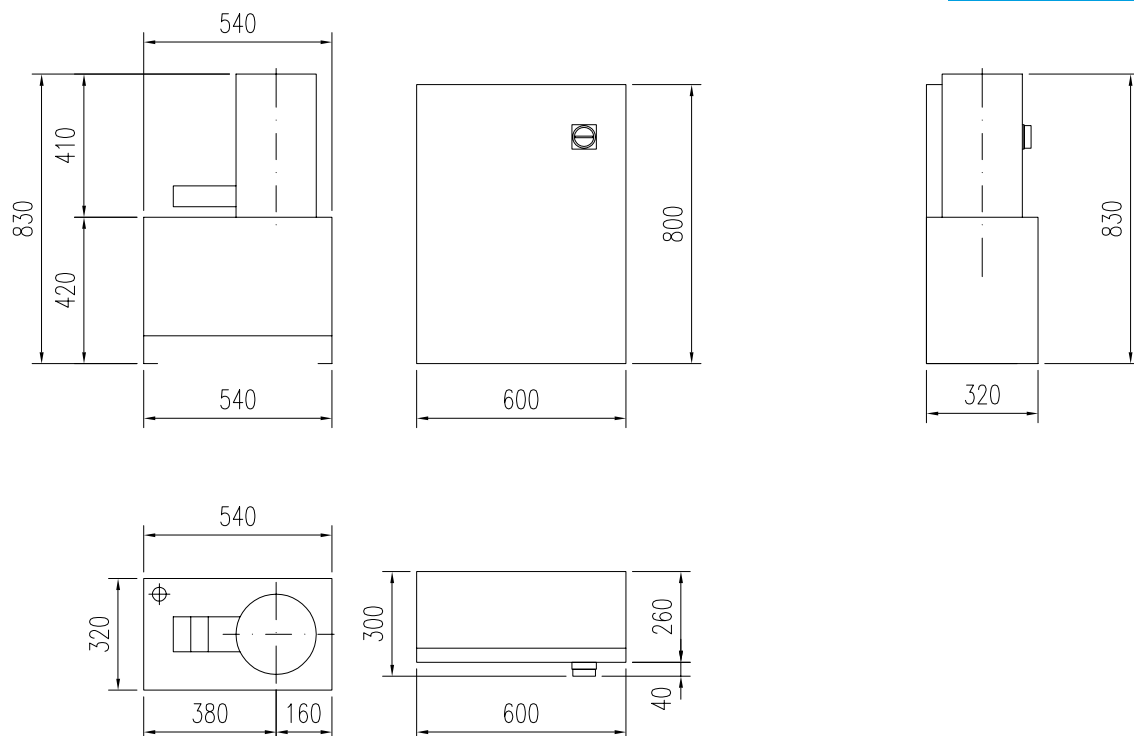

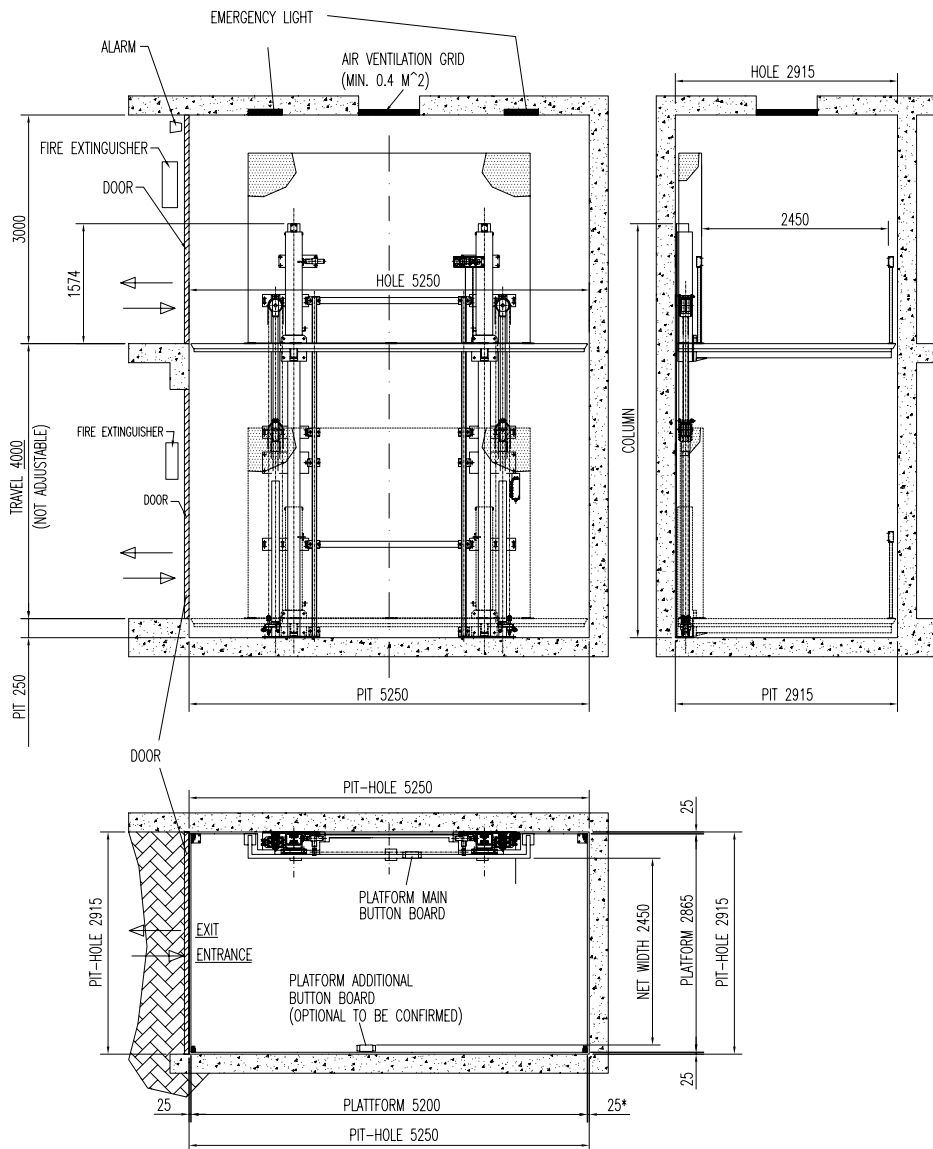

ACCESSORIES

■ STANDARD ITEM □ OPTIONAL ITEM

DESCRIPTION	TOTAL MOVE	NOTES
Standard colours: BLUE RAL 5005 and SILVER RAL 9006	■	
Nr. 2 columns complete with lifting cylinders	■	
Nr. 1 platform in diamond plate	■	
Nr. 1 torsion bar	■	
Nr. 2 "dead man" push-button board	■	
Security control module for sensors and safety locks	■	n.2 electromagnetic sensors included
Nr. 1 Command Board on the platform	■	
Nr. 1 hydraulic control unit with motor 4 KW	■	

ACCESSORIES

■ STANDARD ITEM □ OPTIONAL ITEM

DESCRIPTION	TOTAL MOVE	NOTES
Power Supply: 400-460V/3Ph/50-60Hz	■	
Nr. 1 deceleration kit	■	
Nr. 1 warning siren	■	
Columns side protection panel	■	
Standard height up to 4 mt.	■	
N° 2 stops wheels bars L=745 mm	■	
2 stops	■	
Nr. 2 Light Barriers H=500 mm.	■	
Level locking mechanical devices	■	
Return to floor device (back-up battery)	■	
Nylon Package	■	
Screws anchor	■	
Additional Cost for lifting height over 4 mt. (each 500 mm.)	□	Suitable up to 11 mt.
Extra cost for platform in 4 pieces*	□	
Extra cost for non standard platform size	□	
Additional Cost for the 3rd Stop	□	Suitable up to 6 Stops
Columns split in 2 or more sections	□	Check the shaft access
Lifting speed increase (from 0,06 to 0,12 m/sec)	□	Until a max. of 6,5 m beyond which upon specific request to OMER - Suggested for height over 5 mt.
Additional push button board	□	
Add. Push Button Board with Upright for double Entrance/Exit	□	
Safety lock for concertina and standard doors	□	
Additional electro - magnetic sensor	□	
Outside Pulse Recall for each Push Button Board	□	suitable only for closed shaft
Outside Infra-red Remote Control - Each Receiver	□	max. 5 mt. distance
Outside Infra-red Remote Control - Each Transmitter	□	max. 5 mt. distance
Flashing light	□	
Audible warning kit	□	
Additional warning siren	□	
Two-colours tower light (Red / Green)	□	
Energy Saving Soft Start	□	
Emergency manual pump	□	
Waterproof push-button board IP 65	□	
Additional set of locking cylinder under the platform	□	
Nr. 1 fixed handrail protection without grid H=1.200 mm.(each meter)	□	
Nr. 1 removable handrail protection without grid H=1.200 mm.(each meter)	□	
Non standard colour*	□	
Push button board people lift design*	□	
Console for panel control*	□	
Screw anchors for walls different than concrete.*	□	
Hot Galvanisation (platform,columns and guides)	□	
Hot Galvanisation every 50 cm. Over 4 m. lifting height (each 500 mm.)	□	
Wood Pallet for Columns (nr. 2) Cad	□	
Wood Pallet for Rack	□	
Wood Pallet for Platform	□	
Wood Pallet for Protection	□	
Control Panel Crate	□	
Remote alarm dialer	□	According the standard EN 81-28