

# MOVE 30





# MOVE 300



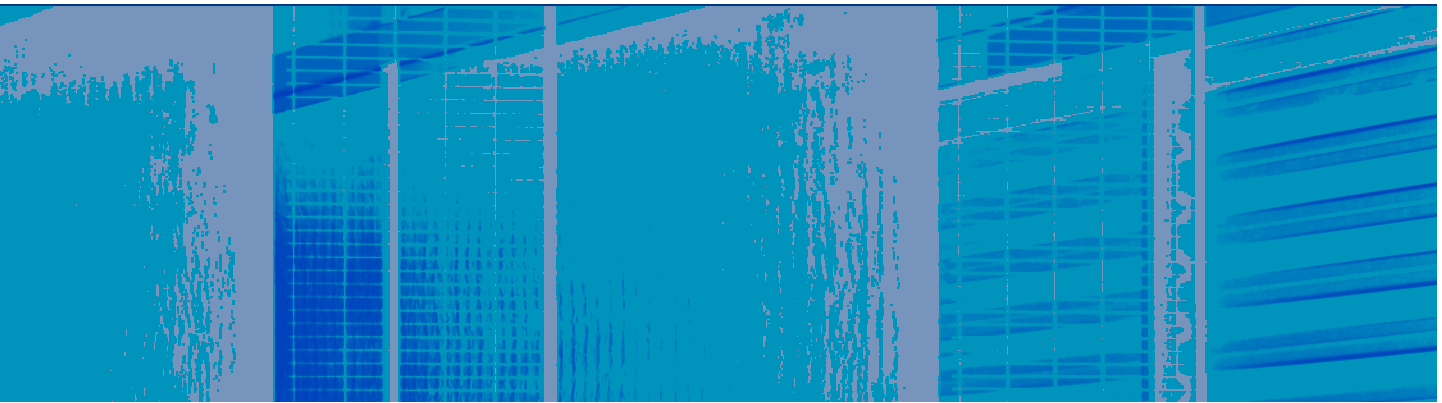

Move 30 N is a platform that runs on two opposing columns that can easily be installed, even in places which do not allow for direct securing to the walls.



## MOVE 30n

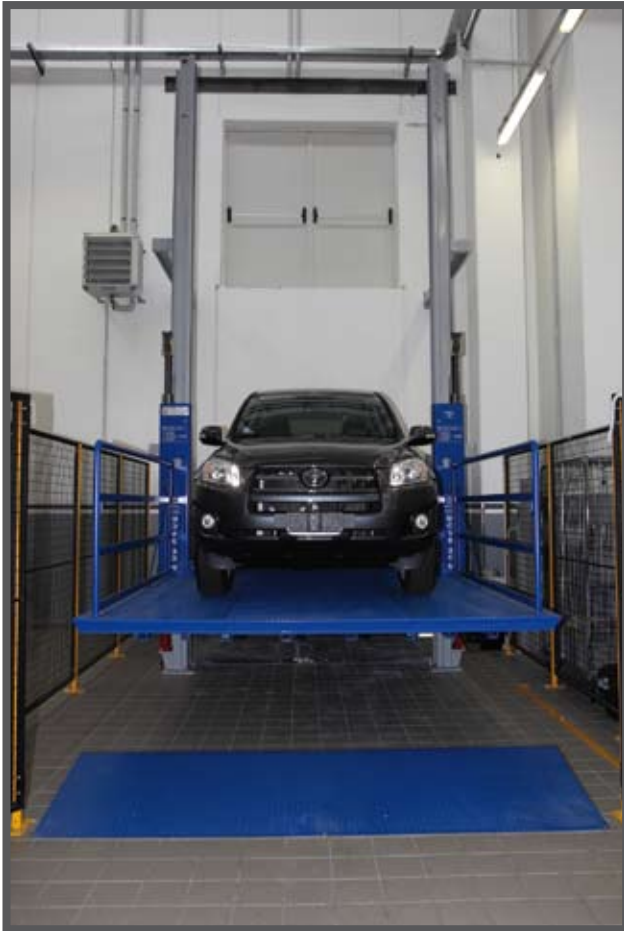

The vehicle can be parked on the platform facing in either direction, forward or back, without affecting the platform balance at all. Moreover, the platform is certified for use up to a height of 11 meters.





The platform is composed of an extremely resistant base structure and no points are subject to bending even though the weight bearing capacity of 3,000 Kg. The relative stability makes this unit extremely safe and easy to drive the vehicle onto the platform.



Move 30 N also has a torsion bar system that prevents the vehicle weight from putting the platform out of balance. Moreover, it ensures greater safety while the platform is moving. The important fact is that the torsion bar slides on a rack which is a self-contained element and thus does not affect the column structure.

a self-contained element and thus does not affect the column structure. The mechanical system locking the platform to the floor is of vital importance. Operated by a hydraulic piston, it ensures perfect platform safety, connecting the shoulder to the piston and preventing untimely movement while the vehicle is being parked on the platform itself. Moreover, when the connection is made, the entire hydraulic system can be set at rest, safeguarding it and extending its lifespan.



Detail of floor level mechanical locking device.

## MOVE 30n

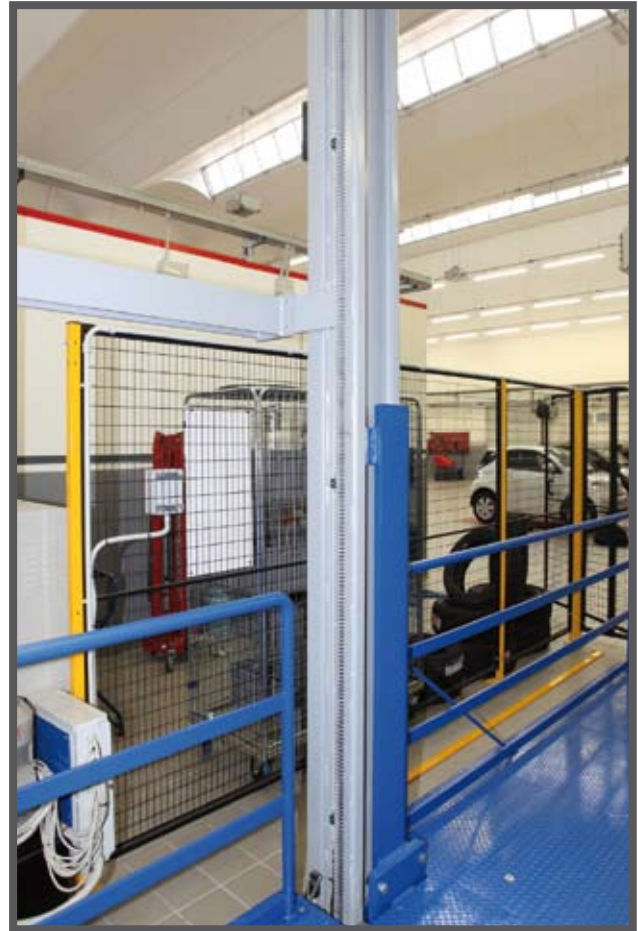

When needed, it is possible to add fixed or mobile protection guards directly on the platform, thus ensuring greater safety while the vehicle is being moved.



The machine is supplied with shims/beams securing it to the nearest wall and ensuring utmost stability and safety. The concept of safety is the common denominator in all O.M.E.R. S.p.A. products.



Move 30 N has a piston (manufactured by O.M.E.R. S.p.A.) with chain (ratio 1:2) so the travel vs. the length of the shaft can be doubled. The top of the piston holds a pulley over which a chain slides; it is protected by a metal plate which prevents the chain from leaving its housing.



Move 30 N has different limit switch systems. The stop limit switch stops the platform at the level indicated and ensures that it is safe to embark or disembark.



Another limit switch serves an extremely important function: deceleration. It ensures that the platform arrives at the desired level gently, without any abrupt movement .



The Move 30 N management and control assembly is quite compact and takes up very little space.

The electric motor is installed over the oil tank and the electrical panel is installed to the side so that all parts allow for quick easy access for functional maintenance.

*SECTION*

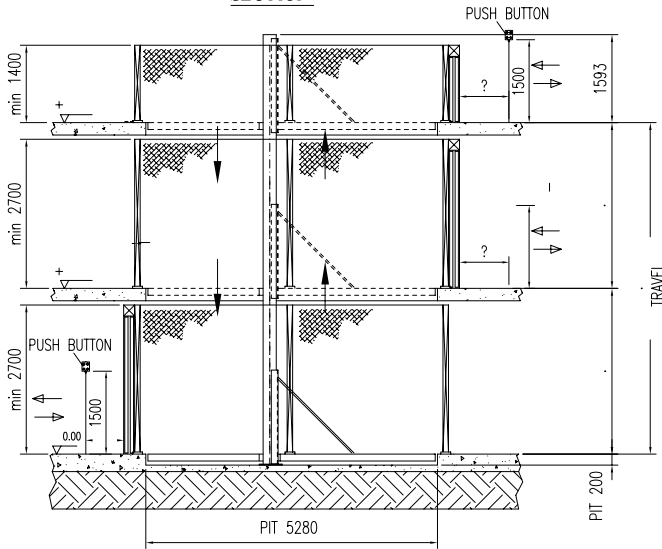

PLEASE DEFINE POSITIONING OF:  
 - HYDRAULIC POWER UNIT  
 - PUSH BUTTON

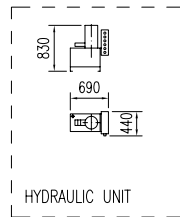

## MOVE 30n 2 embedded stops

*MEZZANINE LEVEL-PLAN*

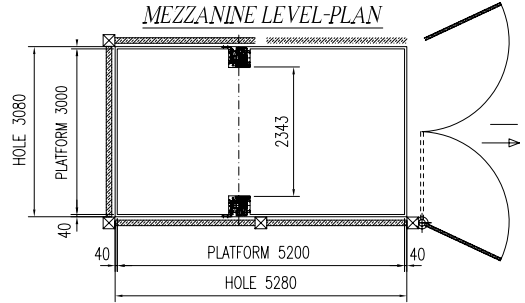

*ENTRANCE LEVEL-PLAN*

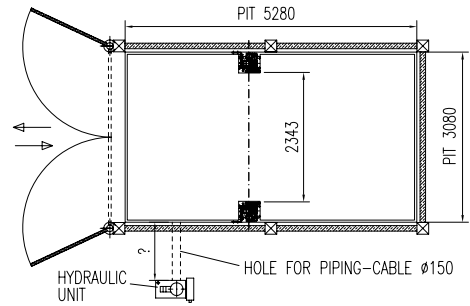

## MOVE 30n 2 embedded stops

*SECTION*

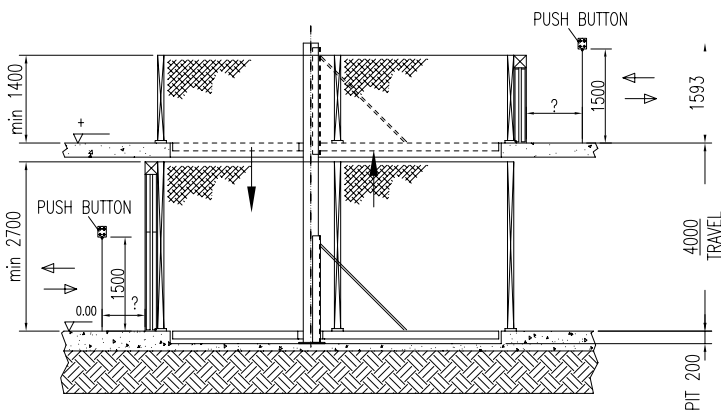

PLEASE DEFINE POSITIONING OF:  
 - HYDRAULIC POWER UNIT  
 - PUSH BUTTON

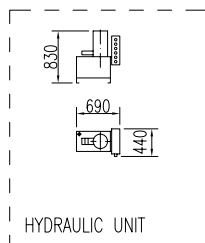

*UPPER FLOOR-PLAN*

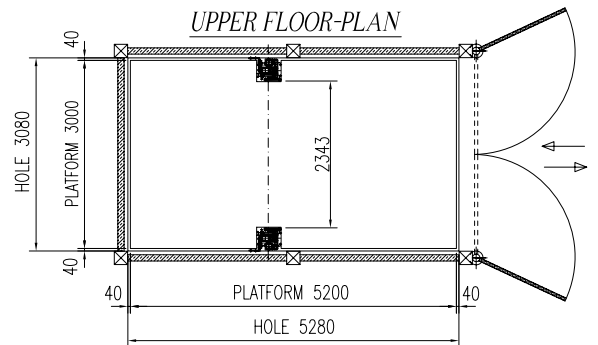

*LOWER FLOOR-PLAN*

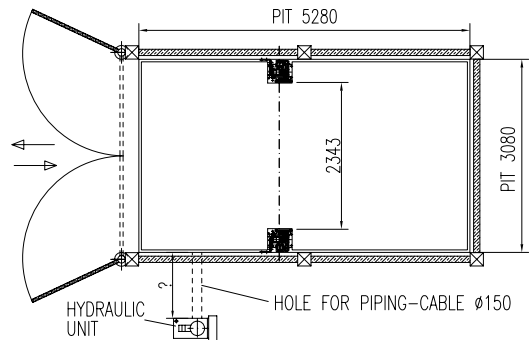

## MOVE 300 2 floor-level stops

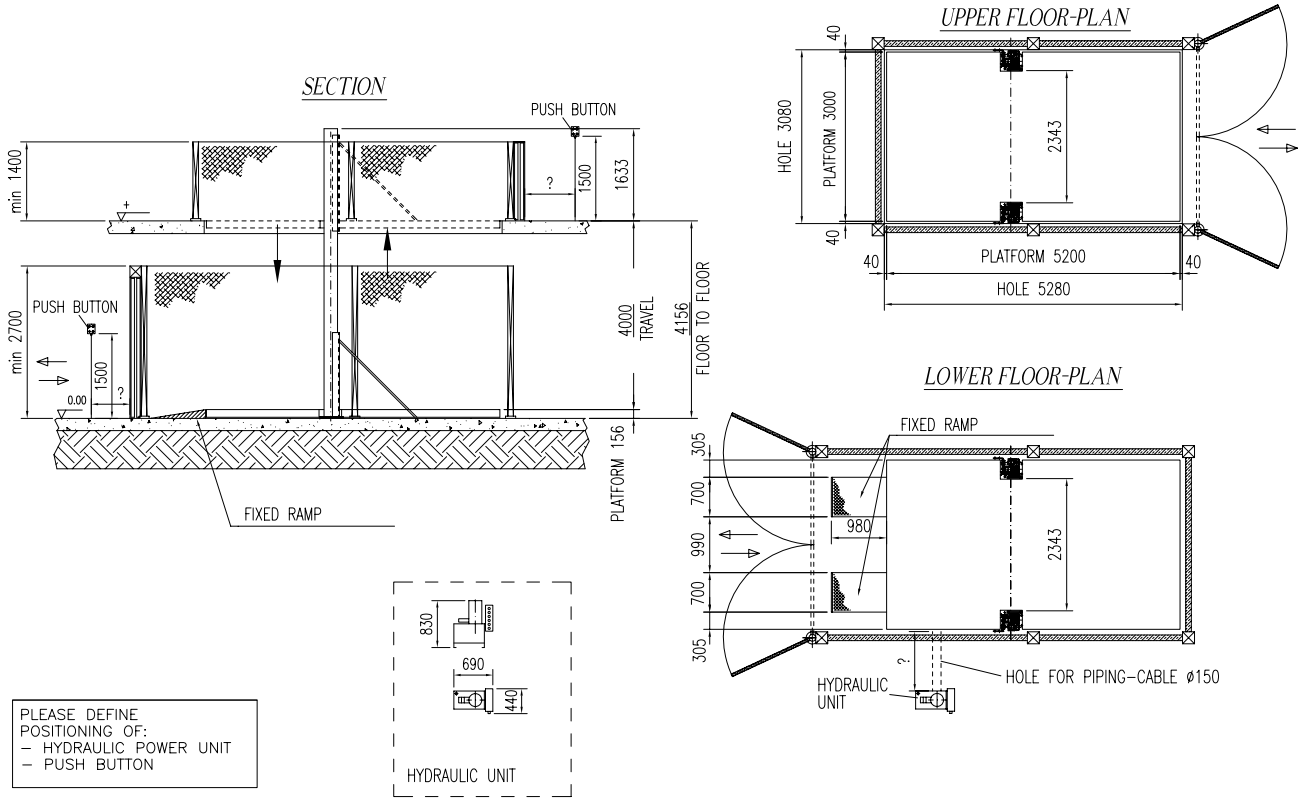

## MOVE 30N 2stops-hidden shoulders

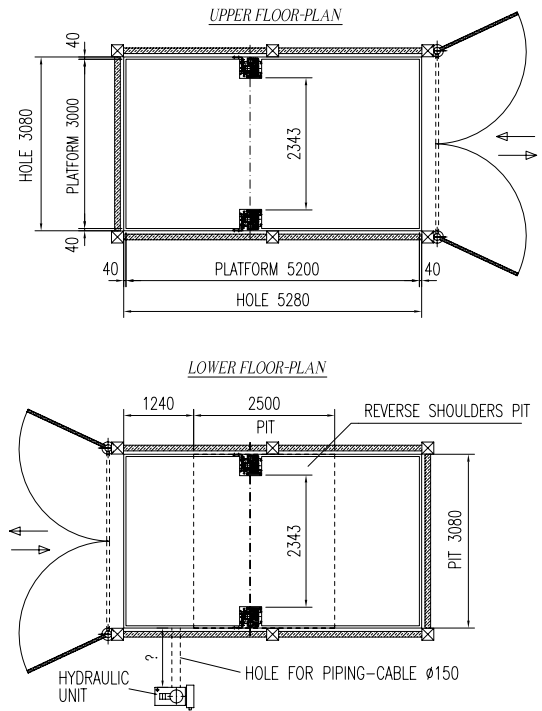
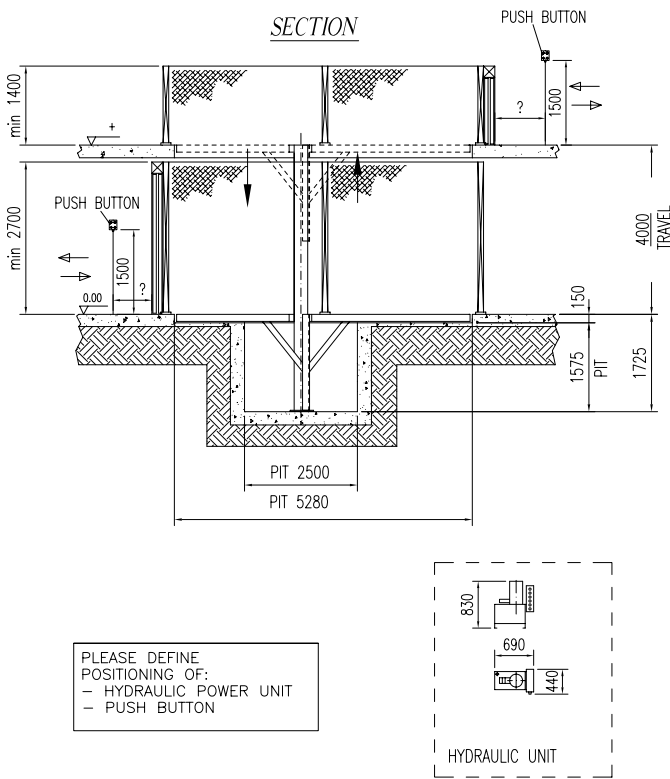

## MOVE 30N 3 floor-level stops

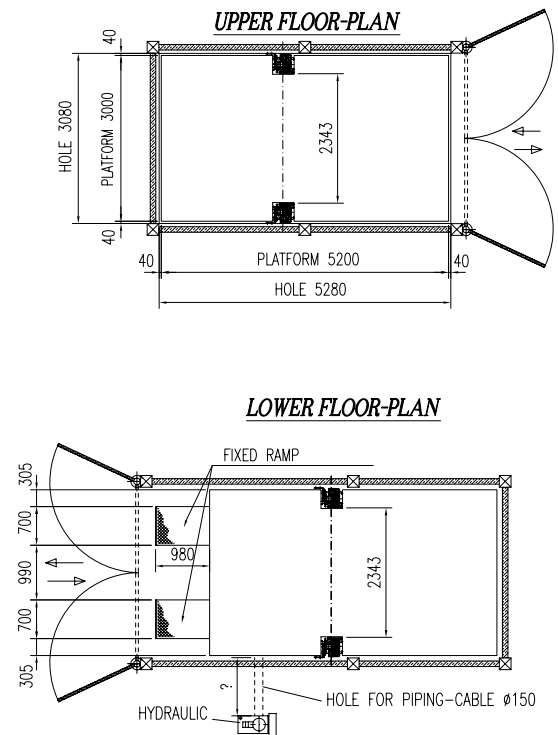
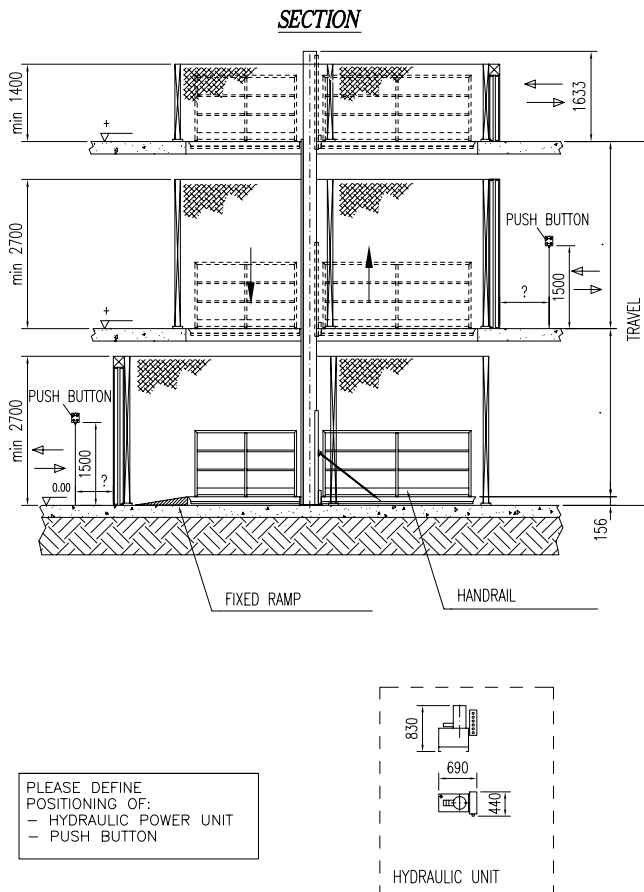

MOVE 300 3 steps front anchoring

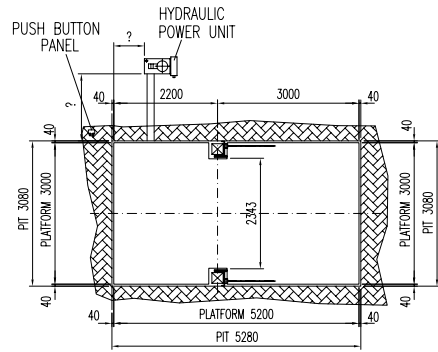
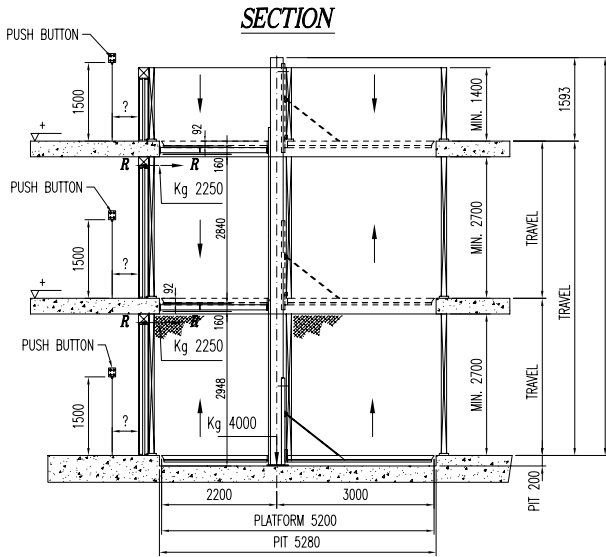

**LOWER PLAN VIEW**

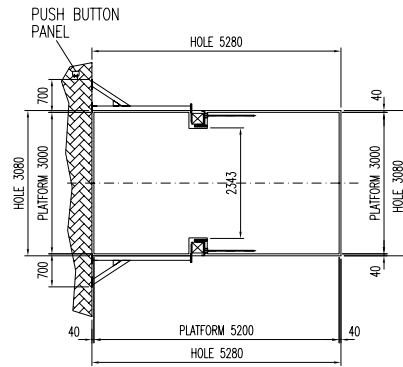

**SECOND AND THIRD PLAN VIEW**

PIT MOVE 300

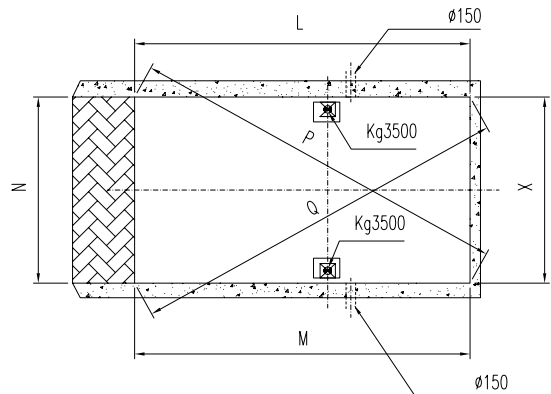
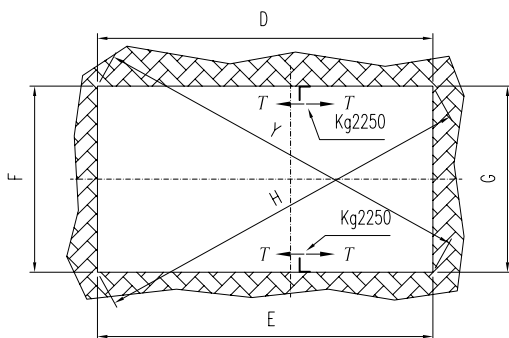
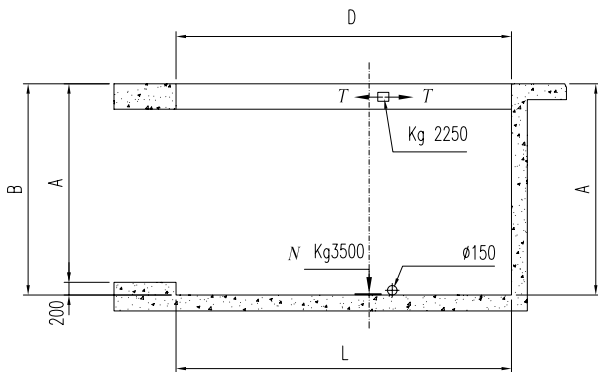

# MOVE 30n

	Capacity	Standard Lifting Height	Max Lifting Height	Minimum Platform	Standard Platform	Max Platform	Pit	Power	Speed	Power supply	Standard Weight	Notes
MOVE 30 N	3.000 kg.	4.000 mm	11.000 mm	2.000x2.000 mm	3.000x5.200 mm	3.000x6.000 mm	200 mm	4/7,5 kw	0,06 m/s	400 v / 50 hz	3.100 kg.	
	6.608 lbs	157,5 inch	433,1 inch	78,7x78,7 inch	118,1x204,7 inch	118,1x236,2 inch	7,9 inch	5,5/10,2 hp	2,4 inch/s	400 v / 50 hz	6.828 lbs	

## ACCESSORIES

■ STANDARD ITEM    □ OPTIONAL ITEM

DESCRIPTION	MOVE 30 N	NOTES
Standard colours: BLU / BLUE RAL 5005 e/and ARGENTO / SILVER RAL 9006	■	
Nr. 2 columns complete with lifting cylinders	■	
Nr. 1 platform in diamond plate	■	
Nr. 1 torsion bar	■	
Nr. 2 "dead man" push-button board	■	
Security control module for sensors and safety locks	■	N.2 electromagnetic sensors included
Nr. 1 hydraulic control unit with motor 4 KW	■	
Motor of the hydraulic control unit of 7,5 KW		
Power Supply: 400-460V/3Ph/50-60Hz	■	
Nr. 1 deceleration kit	■	
Standard height up to 4 mt.	■	
2 stops	■	
N° 2 stops wheels bars L=745 mm	■	
Level locking mechanical devices	■	
Nylon Package	■	
Screws anchor	■	
Roof to cover the entrance hole		Roof transiting capacity: 2000 kg. (Not suitable to lift a vehicle)
Roof for special finishes		Roof transiting capacity: 2000 kg. (Not suitable to lift a vehicle)
Roof stainless steel support frame		
Smooth plate platform set for tiles application	□	Includes 3 cm. height perimeter frame – max. 70 kg. square mt. The pit depth increases 30 mm - The nominal load is reduced according the tiles weight
For Hidden Guides	□	Advised when tiles are installed on the platform
Lifting height over 4 mt. (each 500 mm.)	□	Suitable up to 11 mt.
Travel exceeding 11 mt.		Up to 16 m - preliminary evaluation by OMER is needed
Platform in 4 pieces		
Undersized/oversized non standard platform	□	
Undersized/oversized non platform roof		
Additional Cost for the 3rd Stop	□	Suitable up to 6 Stops
Additional Cost for further Stops	□	
Columns split in 2 or more sections (each section)	□	Check the shaft access

## ACCESSORIES

■ STANDARD ITEM    □ OPTIONAL ITEM

DESCRIPTION	MOVE 30 N	NOTES
Columns split in 2 or more sections	<input type="checkbox"/>	Check the shaft access
Lifting speed increase (from 0,06 to 0,12 m/sec.)	<input type="checkbox"/>	Until a max. of 6,5 mt. Beyond which upon specific request to O.ME.R. S.p.A.)
Additional push button board	<input type="checkbox"/>	
Safety lock for concertina and standard doors	<input type="checkbox"/>	
Additional electro - magnetic sensor	<input type="checkbox"/>	
Outside Pulse Recall for each Push Button Board	<input type="checkbox"/>	Suitable only for closed shaft
Outside Pulse Recall for each Push Button Board	<input type="checkbox"/>	Suitable only for closed shaft
Outside Infra-red Remote Control - Each Receiver	<input type="checkbox"/>	Max. 5 mt. distance
Outside Infra-red Remote Control - Each Transmitter	<input type="checkbox"/>	Max. 5 mt. distance
Flashing light	<input type="checkbox"/>	
Audible warning kit	<input type="checkbox"/>	
Two-colours tower light (Red / Green)	<input type="checkbox"/>	
Energy Saving Soft Start	<input type="checkbox"/>	
Emergency manual pump	<input type="checkbox"/>	
Back-up battery	<input type="checkbox"/>	
Waterproof galvanised cover for control unit for outdoor installation	<input type="checkbox"/>	
Waterproof push-button board IP 65	<input type="checkbox"/>	
Additional set of locking cylinder under the platform	<input type="checkbox"/>	
Set of 2 frontal anchoring support	<input type="checkbox"/>	
Set of 2 anchoring floor supports	<input type="checkbox"/>	
Nr. 1 fixed handrail protection without grid H=1.200 mm.(each meter)	<input type="checkbox"/>	
Nr. 1 removable handrail protection without grid H=1.200 mm.(each meter)	<input type="checkbox"/>	
Ground fixed two-piece access ramps	<input type="checkbox"/>	Subject to OMER checkout
Ground fixed one-piece long access ramp	<input type="checkbox"/>	Subject to OMER checkout
Mobile two-piece access ramps on the platform	<input type="checkbox"/>	Subject to OMER checkout
Light Barriers (Nr. 2)	<input type="checkbox"/>	
Roof Car Presence Sensor (Nr. 2)	<input type="checkbox"/>	
Non standard colour*	<input type="checkbox"/>	
Push button board people lift design*	<input type="checkbox"/>	
Console for panel control*	<input type="checkbox"/>	
Screw anchors for walls different than concrete.*	<input type="checkbox"/>	
Hot Galvanisation (platform,columns and guides)	<input type="checkbox"/>	
Hot Galvanisation every 50 cm. Over 4 m. lifting height (each 500 mm.)	<input type="checkbox"/>	
Frontal Anchoring hot galvanisation	<input type="checkbox"/>	
Floor anchoring galvanisation	<input type="checkbox"/>	
Roof hot galvanisation (standard dimensions)	<input type="checkbox"/>	
Hot galvanisation of the fixed two-piece access ramps	<input type="checkbox"/>	
Hot galvanisation for mobile two pieces access ramps on the platform	<input type="checkbox"/>	
Hot galvanisation of the fixed long access ramp	<input type="checkbox"/>	
Wood Pallet for Columns (nr. 2) Cad	<input type="checkbox"/>	
Wood Pallet for Rack	<input type="checkbox"/>	
Wood Pallet for Platform	<input type="checkbox"/>	
Control Panel Crate	<input type="checkbox"/>	