



RALLA



RALLA



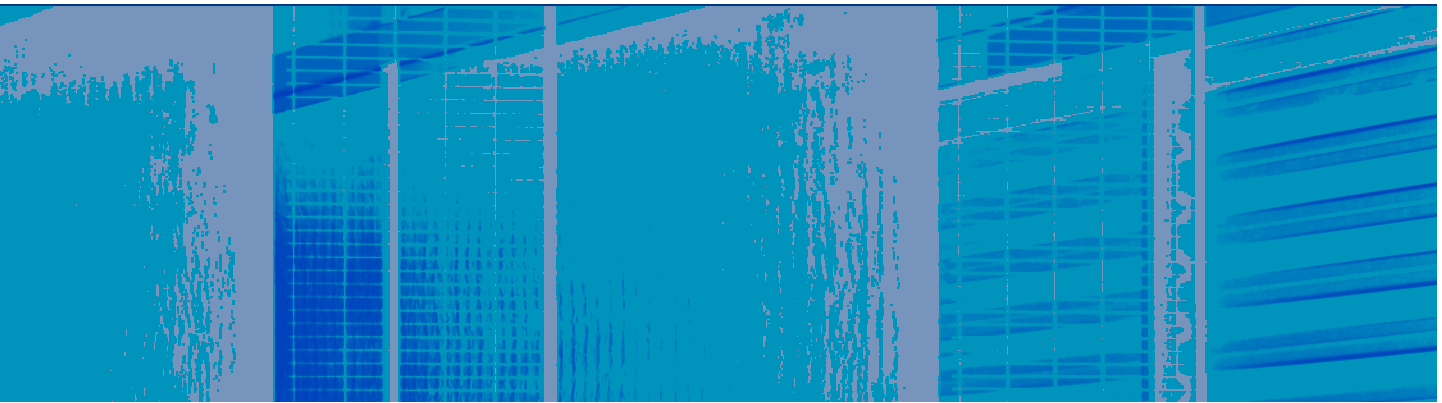

Ralla 25 is a turntable platform ideal for those spaces where maneuvering the vehicle would prove extremely complex. Easy to use, Ralla 25 also comes in a version that can be tiled to match the surrounding grade, thus making it even more attractive.

Essentially, the Ralla 25 has eleven main structural elements:

- Four platform wedges
- Four wheel guides embedded in the construction work
- A structure connecting to the underlying circular rack
- Panel covering the connection structure
- Motor assembly

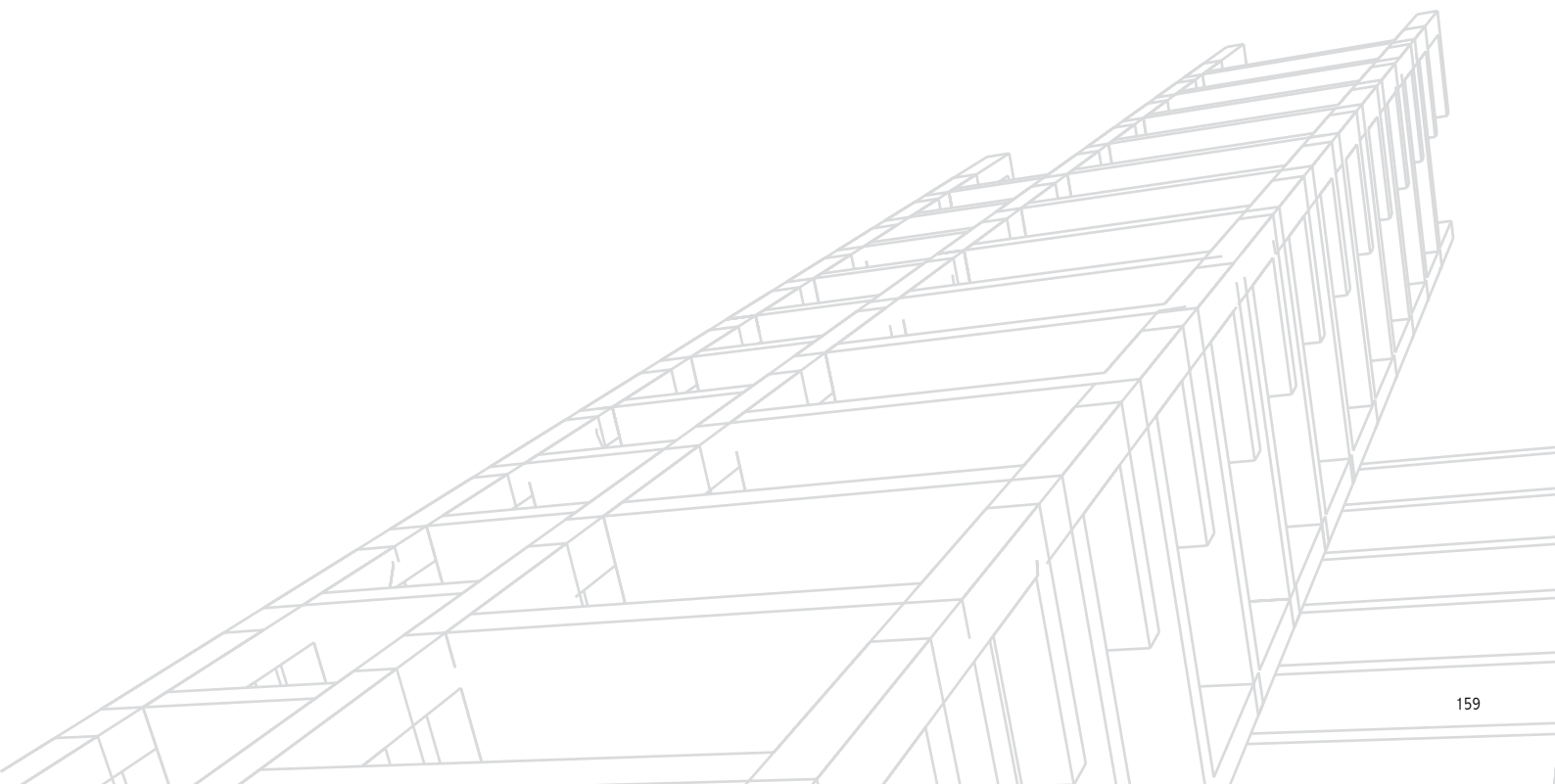

RALLA



Each of the wedge-shaped sections of the Ralla 25 has four polyurethane wheels, reducing the amount of unsupported space to the barest minimum and thus preventing deformation of the platform due to uneven weights. This also significantly reduces noise.



The polyurethane wheels are secured to the structure with mechanical pins, hooked onto a "U"-shaped structure welded to the platform.



The connection structure is a cross-shaped element welded on the top.

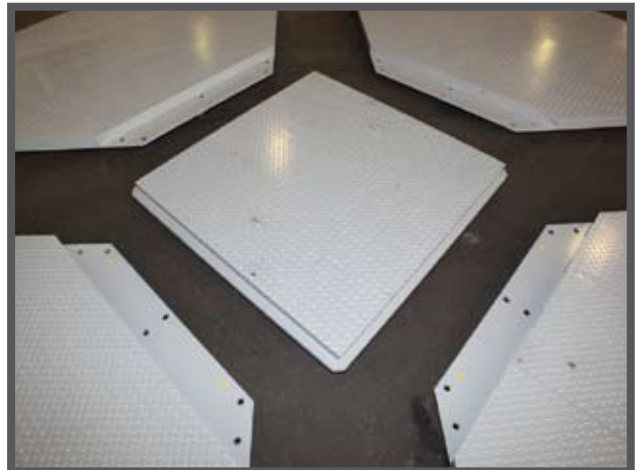

Once the four sections of the platform have been secured to the connection structure, they are closed by a covering panel that ensures a uniform finish.



One of the four sections has a hatch for inspection of the motor and for maintenance.

The pit edging profile also serves as track for the wheels, thus preventing the wear that would ensue if they ran on rough concrete. Each part of the edge has a flange for securing to the next part, thus ensuring that it creates a solid guide structure. Moreover, some iron consolidation pieces are welded on the back of the guide to ensure that the unit is solidly secured to the concrete.



The connection structure is snapped into the central rotation pin in the underlying area.



The central rotation pin - set on the motor assembly and fit with thrust bearings to completely absorb compression due to weight - is used to accommodate the connection structure.

RALLA



The gearmotor is one with the structure supporting the central rotation pin. The gearmotor is built so that it is easy to install and does not allow for coupling errors.

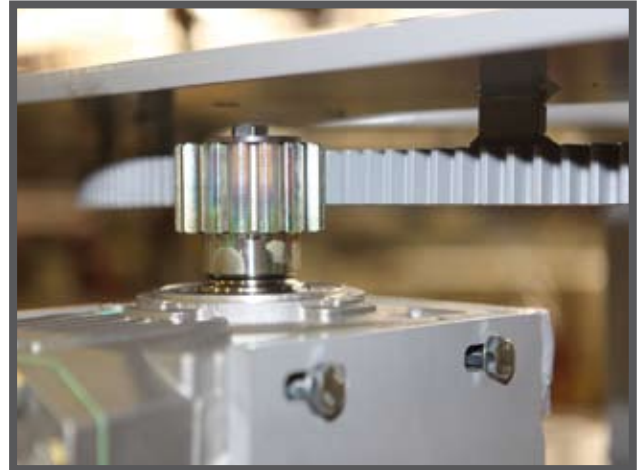

The rotation pinion is coupled to the turntable's circular rack by shifting the gearmotor assembly forward and back. This movement is enabled by just two slots located on the side of the assembly itself; moreover, once coupling has been completed, it can be locked in place with two securing bolts.



Detail of the circular rack applied to the turntable connection structure on the central rotation pin.



The gearmotor assembly - with central rotation pin and rotation pinion - is connected to the circular rack.



Detail of the gearmotor with rotation pinion. This photo shows the slots, fit with securing bolts, set on both the front (for right - left adjustment) and on the side (for forward - back adjustment).



Finally, the pushbutton control panel with buttons to control clockwise and counter-clockwise rotation plus emergency button and safety key.

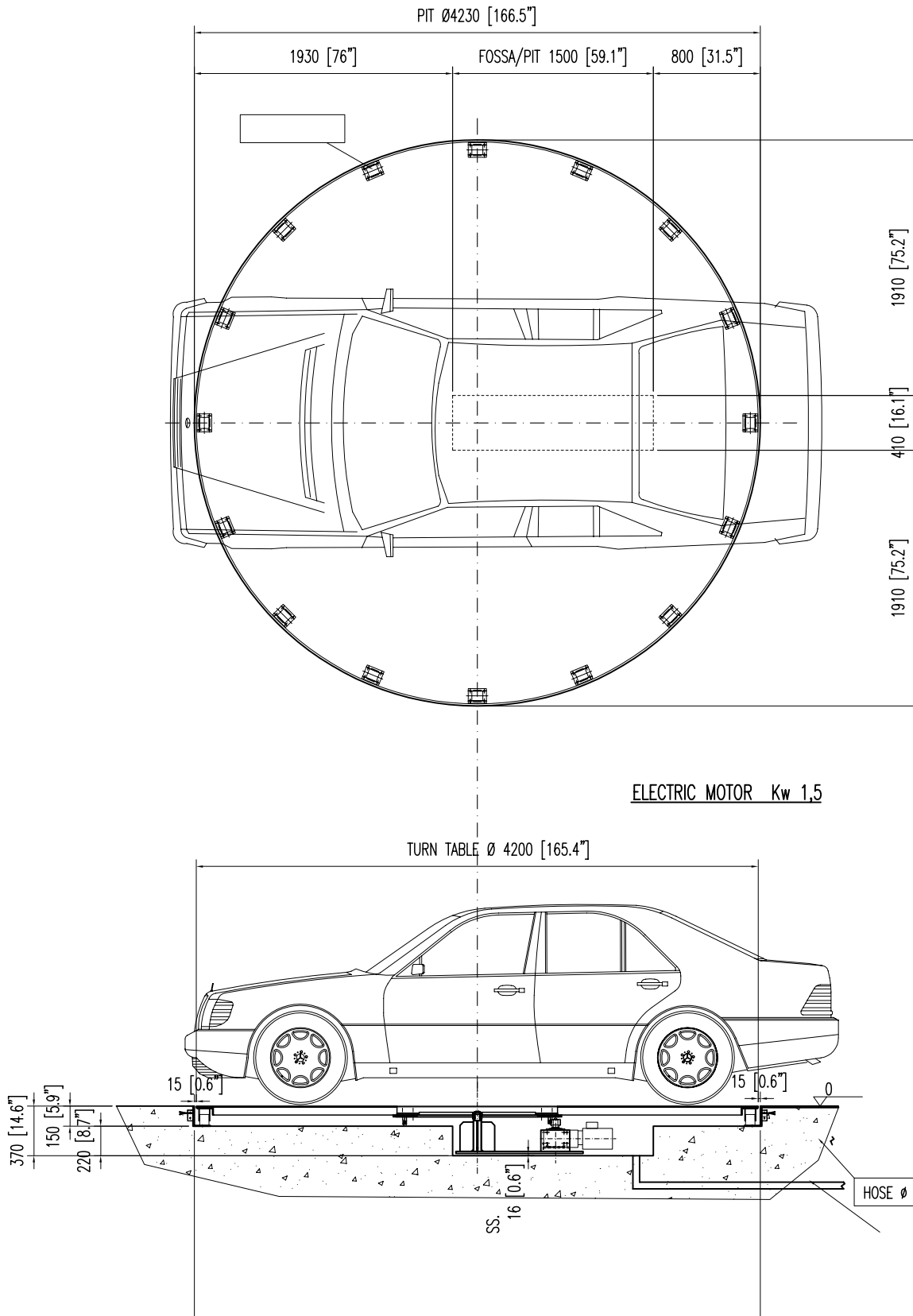

	Capacity	Standard Diameter	Pit	Power	Speed	Power supply	Standard Weight	Notes
RALLA	2.500 kg.	4.200 mm	150 mm	1,5 kw	1,4 rpm	400 v / 50 hz	1.300 kg.	
	5.500 lbs	165,4 inch	5,9 inch	2 hp	1,4 rpm	400 v / 50 hz	2.860 lbs	

ACCESSORIES

STANDARD ITEM OPTIONAL ITEM

DESCRIPTION	TOTAL MOVE	NOTES
Standard colours: BLUE RAL 5005 and SILVER RAL 9006	■	
Nr. 1 diamond plate platform in 4 sections – 4.200 diameter	■	
Nr. 1 pit frame hot galvanised in 4 sections	■	
Nr. 1 Motor + Gear box 1,5KW	■	
Power Supply: 230-400V/3Ph/50-60Hz	□	
Nr. 1 Trap door to allow motor/gear inspection	■	
Nr. 1 "dead man" push-button board	■	
Nylon Package	■	The pit depth increases of 30 mm
Smooth plate platform set for tiles application	□	Tiles weight up to 70 kg/square mt. The pit depth increases in order to take into account the tiles thickness.
Flashing light	□	
Audible warning kit	□	
Radio remote control (receiver, antenna, N° 1 transmitter)*	□	
Transmitter*	□	
Ar Presence Sensors kit	□	
Non standard power supply - 220V/1Ph/50-60Hz	□	
Hot Galvanisation	□	
Wood Pallet for Ralla 25 Platform - 4 pcs.	□	
Wood Pallet for Ralla 25 Structure	□	
Control Panel Crate	□	